



# ISOLED KNOWLEDGE

---

## DALI

Digital Addressable  
Lighting Interface

**ISOLED**<sup>®</sup>

CUSTOMISED LIGHT SOLUTIONS



## DALI - SIMPLE, UNIQUE AND AFFORDABLE!

### Intelligent lighting management

DALI (Digital Addressable Lighting Interface) was developed by a working group of the German Lighting Association (ZVEI) and is a manufacturer-independent international interface standard for dimmable electronic control gear.

DALI is used in the field of building automation for simple and uncomplicated control of lighting solutions at room level. The integration into building-wide systems such as z. e.g. KNX (higher-level fieldbus for cross-room building automation) is possible via bridges.

### Light scenes perfectly adapted to the use

The control gear (such as sensors, electronic control gear, luminaires etc.) with a DALI interface are assigned unique DALI short addresses, via which the DALI control unit (or DALI gateway) queries the status of the lamps and control gear and sets them to the desired operating state (switch on/off, dimming level).

Up to 16 lighting scenarios can be defined, programmed and thus implemented with the DALI lighting management system.

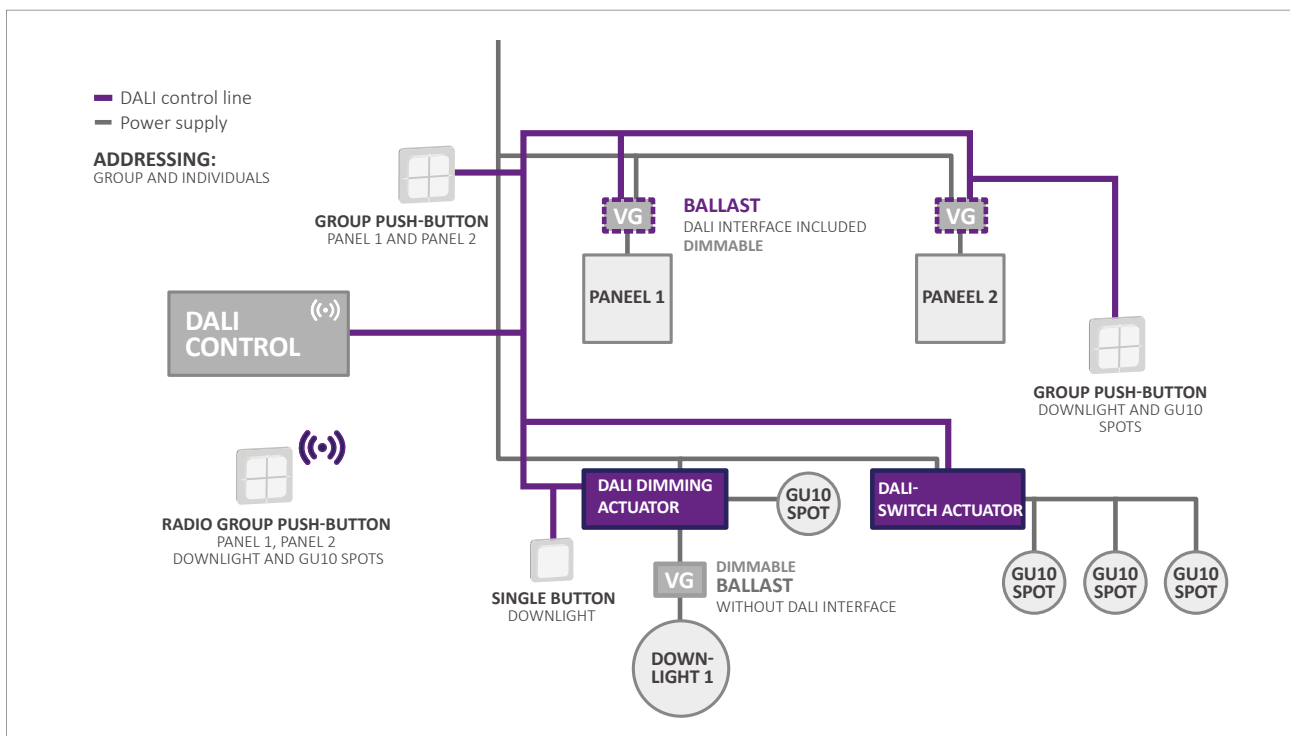

Max. 300 metres DALI control cable

Maximum of 64 control gear units can be connected

Up to 16 groups

16 lighting scenarios can be realised





### Simple planning and cost-effective Installation

The DALI bus system has established itself on the market compared to the common 1-10 V standard (ECGs with analogue 1 to 10 V interface) and is also considered the successor to the DSI (Digital Serial Interface). DALI offers a much greater range of functions, is very easy to use and is cost-effective to install.

Unlike these two systems, the DALI bus system allows each individual control gear to have different intensity control values and each of them reports these back (bidirectional information flow). With 1-10 V standard and DSI, only a uni-directional information flow is possible (from controller to control gear).

### High interference immunity and a wide range of structural options for cabling

The DALI bus system uses a serial, asynchronous data protocol (transfer rate 1200 bit/s at a voltage level of 16 V). This ensures high immunity to interference and allows the two free wires of the 230 V cable to be used for the DALI bus-> simple and cost-effective installation!

The lines for data transmission can be star-, line- or

or tree-shaped, whereby the maximum distance between two system components, depending on the cable cross-section, cannot exceed a length of 300 m.

No terminating resistors are required at the ends of the cables. No ring-shaped connection of components! Compared to conventional cabling, where all the luminaires in a line can only be switched and dimmed synchronously, the assignment of switches and luminaires in a DALI system can be changed at any time without having to re-cable.

### Low cost, few components, easy programming

- » A 2-wire control line can be used to control up to 64 actuators/control gear individually and/or in max. 16 groups per DALI bus system- NO group wiring or relays required!
- » Each control gear has its own DALI short address, is programmed centrally, can be assigned to several groups and can perform synchronous tasks within these groups or be controlled for individual settings
- » Max. 16 light scenes (intensity control values) per DALI control gear can be defined and stored- when a lighting scene is called up, all DALI ECGs reach their dimming setpoint synchronously
- » Max. 250 mA current consumption per DALI bus
- » Up to 2 mA current consumption per DALI load (DALI actuator)- so the control gear does not need its own power supply
- » Max. voltage drop between transmitter unit and actuator NOT below 2 V
- » Max. 300 m length of connecting cables when using conductors with 1.5 mm<sup>2</sup> cross-section (Note: If the maximum length of 300 m is required, the combined use of the mains cable is not recommended)
- » The „free“ lines of a 5 x 1.5 mm<sup>2</sup> NYM cable of the mains supply (230 V) can be used as control lines
- » The polarity of the control lines need not be observed for DALI ballasts
- » No ring-shaped installation of the DALI bus system possible- otherwise cables can be installed in almost any topology!

If the required insulation conditions (double insulation) are met, the „free“ lines of a 5 x 1.5 mm<sup>2</sup> NYM cable of the mains supply (230 V) can be used for the control lines of the digital interface. See illustration.

A major advantage: the DALI bus system does not need its own connecting lines and can therefore be installed very easily and cost-effectively.

